

MD.2 Users Manual



Interactive Medical Developments, L.C.

MD.2 Users Manual

Revision II

04/03

### **Disclaimer**

The information in this document is subject to change without notice. While the information contained is accurate to the best of our ability, Interactive Medical Developments assumes no liability or responsibility for omissions or errors.

**A word about safety...**

A personal note to the CAREGIVER from Interactive Medical Developments, L.C.:

Dear CAREGIVER:

If you are uncertain as to whether the MD.2 Unit is appropriate or suitable for use by a person for whom you have accepted “Caregiver” healthcare responsibilities, check with a physician or other healthcare specialist familiar with the person’s current physical and mental condition.

The MD.2 Unit is provided to you at your request to assist you in the delivery of healthcare medications to a person for whom you have accepted “CAREGIVER” healthcare responsibility. Its sole purpose is to assist in dispensing medication. Interactive Medical Developments, L.C. relies on you to provide timely and accurate information to fulfill the medication delivery function of the MD.2 Unit.

Always keep the **machine locked at all times**.

It is **NOT** the purpose of the MD.2 Unit to serve as an alternative monitoring system for patient well being or for any other purpose other than the delivery of healthcare medication according to its design. The MD.2 Unit can only provide its medication dispensing function with your careful assistance and follow up.

Thank you for choosing the MD.2 Unit to assist you in health care.

Interactive Medical Developments, L.C.

SAFE USE INSTRUCTIONS,  
OPERATION INSTRUCTIONS AND  
THE LIMITED WARRANTY OF THE  
MD.2 MEDICATION DISPENSING UNIT.

**BEFORE YOU USE THIS MD.2 MEDICATION DISPENSING AND MONITORING SYSTEM, BE SURE TO READ AND UNDERSTAND THESE SAFE USE AND USER'S MANUAL & INSTRUCTIONS. IF YOU DO NOT UNDERSTAND THESE INSTRUCTIONS, CALL YOUR CUSTOMER SUPPORT CENTER AND YOUR QUESTIONS WILL BE ANSWERED. DO NOT USE THE MD.2 MEDICATION DISPENSING SYSTEM UNTIL YOU, YOUR CAREGIVER, OR OTHER PERSON RESPONSIBLE FOR LOADING AND SETTING UP THE UNIT, UNDERSTAND THESE INSTRUCTIONS COMPLETELY.**

As you know, medication and drugs taken other than as prescribed by a medical practitioner, pharmacy, or drug manufacturer may cause serious injury and death. If the MD.2 Medication Dispensing System is not used in conformity with the prescribed medication dosage, amount, frequency of use, and medication instructions furnished to Interactive Medical Developments, L.C. by you, your caregiver or your authorized healthcare provider, serious injury or death may result. Interactive Medical Developments, L.C. relies on you to assure the accuracy, compatibility, completeness, timeliness, and correct information so that the MD.2 Medication Dispensing System may perform according to its designed purpose.

This document contains important product information, instructions for safe use and operation. ***PLEASE SAVE THESE INSTRUCTIONS.*** You may want to make reference to it in the future as it contains important information about the operation, safe use and maintenance of this MD.2 Medication Dispensing System. The unit serial number for your MD.2 Medication Dispensing unit is located on the right panel inside the locked door.

## I. SAFE USE INSTRUCTION

### **▲WARNING**

- DO NOT use this MD.2 Medication Dispensing System to dispense medication in any way which is not in compliance with the prescription or directions of your prescribing medical practitioner, pharmacy or drug manufacturer.
- DO NOT load any medication into this machine that is used for emergency or life threatening conditions, such as sublingual nitroglycerin.
- DO NOT fail to immediately report any malfunction or operational failure of this MD.2 Medication Dispensing System directly to your Customer Support Center.

- DO NOT fail to call your Customer Support Center with any question about the operation of this MD.2 Medication dispensing System.
- DO NOT use the MD.2 Medication Dispensing System to dispense any liquids, injectables or patches. Attempting to load these substances will damage either the unit or the medication and will void all warranty claims.
- ALWAYS lock the MD.2 Medication Dispensing Unit after loading medication according to the User's Manual & Instructions.
- ALWAYS immediately report any failure to dispense medication according to prescribed medication dosage and frequency to your Customer Support Center.
- NEVER permit medication to be used in this MD.2 Medication Dispensing System by any individual who has not read, understood the User's Manual & Instructions.
- DO NOT attempt to take apart, modify or in any other way tamper or attempt repair of the MD.2 other than what is outlined in the User's Manual. Any tampering or attempt to modify or repair this unit will immediately void all warranty claims.
- NEVER permit children to have access to or tamper with the machine. ALWAYS KEEP OUT OF REACH OF CHILDREN.

## II. OPERATING INSTRUCTIONS

The attached User's Manual, with written instructions, is enclosed with the MD.2 Medication Dispensing and Monitoring System. It provides complete information about the safe use, operation and maintenance of the unit.

**BEFORE YOU USE THIS MD.2 MEDICATION DISPENSING AND MONITORING SYSTEM, BE SURE TO READ AND UNDERSTAND THESE INSTRUCTIONS. IF YOU DO NOT UNDERSTAND THESE INSTRUCTIONS, CALL YOUR CUSTOMER SUPPORT CENTER. DO NOT USE THE MD.2 MEDICATION DISPENSING SYSTEM UNTIL YOU, YOUR CAREGIVER, OR OTHER PERSON RESPONSIBLE FOR LOADING AND SETTING UP THE UNIT, UNDERSTAND THESE INSTRUCTIONS COMPLETELY.**

<b>1. INTRODUCTION.....</b>	<b>5</b>
<b>2. DESCRIPTION OF THE SYSTEM .....</b>	<b>6</b>
THE MD.2.....	6
THE SUPPORT CENTER.....	7
THE CAREGIVER.....	7
<b>3. LIST OF EQUIPMENT .....</b>	<b>8</b>
<b>4. YOUR NEW MD.2.....</b>	<b>9</b>
PHYSICAL DESCRIPTION OF DISPENSING SYSTEM.....	9
KEYPAD OVERVIEW.....	10
<i>Run</i> .....	10
<i>Load</i> .....	10
<i>Setup</i> .....	11
<i>Help</i> .....	11
<i>Status</i> .....	11
<i>Early Dose</i> .....	11
<i>Schedule</i> .....	11
<i>OK</i> .....	11
<i>Left &amp; Right Arrows</i> .....	12
<i>Up &amp; Down Arrows</i> .....	12
UNPACKING AND PREPARING YOUR MD.2 FOR USE.....	12
POWERING UP THE UNIT.....	13
<b>5. SETTING UP THE MD.2 .....</b>	<b>14</b>
INFORMATION SHEETS.....	14
SETTING UP THE MD.2.....	16
DOWNLOADING THE SCHEDULE.....	17
<b>6. LOADING THE MD.2 .....</b>	<b>18</b>
LOAD CAPACITIES.....	18
PROCEDURE FOR FILLING MEDICATION CUPS.....	19
LOADING AN EMPTY MD.2.....	20
INITIAL LOADING OF DAILY MEDICATIONS.....	20
RE-LOADING OF DAILY MEDICATIONS.....	21
<b>7. ADJUSTING YOUR MD.2 .....</b>	<b>23</b>
SET UP KEY.....	23
<i>Time</i> .....	23
<i>LCD (Screen Brightness)</i> .....	23
<i>Volume</i> .....	23
<b>8. OPERATING THE MD.2 .....</b>	<b>24</b>
NORMAL OPERATING MODE.....	24
<b>9. ADDITIONAL FEATURES.....</b>	<b>26</b>
EARLY DOSE FEATURE.....	26
STATUS FUNCTION.....	26
REVIEWING MEDICATION.....	27

<b>10. UNLOADING MEDICATION FROM THE MD.2.....</b>	<b>30</b>
UNLOADING MEDICATION CUPS .....	30
PURGE.....	31
<b>11. TELEPHONE FUNCTIONS AND FEATURES.....</b>	<b>32</b>
CAREGIVER TELEPHONE MESSAGES .....	32
<b>12. TROUBLE-SHOOTING .....</b>	<b>34</b>
MACHINE ERROR MESSAGE .....	34
<i>Removing Jammed Cups.....</i>	34
MACHINE STOPPED MESSAGE .....	35
<i>Manual Unloading When Medication Cup Cylinder Turns Freely.....</i>	36
<i>Manual Unloading When Medication Cup Cylinder Is Stuck.....</i>	36
<i>Re-assembling the Unit.....</i>	37
<b>13. FREQUENTLY ASKED QUESTIONS .....</b>	<b>38</b>
<b>14. LIST OF IMPORTANT PHONE NUMBERS .....</b>	<b>43</b>
<b>15. REGULATORY AGENCY INFORMATION .....</b>	<b>43</b>
TELEPHONE CONNECTION INFORMATION .....	43
<i>Telephone Company Information .....</i>	43
FCC EMISSIONS COMPLIANCE STATEMENT .....	43
CANADIAN EMI SPECIFICATION COMPLIANCE STATEMENT.....	44
<b>APPENDIX A .....</b>	<b>45</b>
MEDICATION MESSAGE LIST.....	45
<b>APPENDIX B</b>	
<b>WORKSHEETS</b>	
<i>USER MEDICATION SCHEDULE &amp; WORKSHEET</i>	
<i>USER &amp; CAREGIVER WORKSHEET</i>	

## 1. Introduction

Congratulations and thank you for choosing Interactive Medical Developments, L.C. (IMD) MD.2. The MD.2 has been designed for anyone looking for help in taking their medication. Your new MD.2 system addresses medication-scheduling problems by providing a simple to use, reliable medication delivery system.

Key benefits of the MD.2 include:

- Medication is delivered at a time you set. Loaded properly, the MD.2 cannot double or overdose medication to the user.
- The delivery unit is simple to use. Medication is delivered with the push of a button.
- The MD.2 uses a number of gentle but effective attention getting techniques to let you know when your medication should be taken.
- The MD.2 holds from 10 days to over 1 month's worth of medication.
- The MD.2 helps maintain a level of independence for the user.
- The MD.2 provides "peace of mind" for the caregiver by relieving the stress, worry and time associated with medication delivery to the user.

## 2. Description of the System

The MD.2 has three elements: the medication delivery unit, your Customer Support Center, and the caregiver.

### ***The MD.2 Capacity***

#### **▲WARNING**

The MD.2 delivers medication in special FDA/USDA approved 1 oz. plastic cups and lids. Each cup is filled with one dosing period of capsule or pill medication. ***Liquids, inhalants, patches and injectables cannot be dispensed from the MD.2. Never load nitroglycerin into the MD.2. However, reminder messages to use this type of medication can be included in the medication schedule.*** The medication cups are easily handled, filled and opened. They provide clean, sealed storage for the medication.

The MD.2 can deliver up to 6 medication cups per day. Each medication cup is delivered to the user at a scheduled time of the day. The schedule is loaded into the MD.2 by the Customer Support Center, via telephone connection. Schedule information needs to be entered once, and can be easily adjusted as medication needs change.

The total medication capacity of the MD.2 depends on the number of cups to be delivered per day. Table 2-1 summarizes the medication handling capacity of the MD.2.

Table 2-1. Medication Deliveries / Day and MD.2

Delivery Rate	Capacity, # Days
1 delivery /day	40 days
2 delivery /day	30 days
3 delivery /day	20 days
4 to 6 delivery /day	10 days

The MD.2 uses several ways to get your attention when it is time to take your medication. To communicate medication reminders and directions, the unit announces voice messages. Additionally, these messages are printed on the front of the machine. A bright red light also flashes when medication is available for delivery.

The MD.2 attempts caregiver phone notification when:

1. The user misses their medication;
2. The MD.2 is almost out of medication;
3. The MD.2 detects that its batteries are low;

4. The MD.2 detects that AC power has been interrupted for any period of time (temporary power outage);
5. The MD.2 is allowed to go empty;
6. The MD.2 flashes a machine error.

The MD.2 calls the caregiver(s) and informs them (via a pre-recorded voice message) of an above mentioned problem or event. During the phone notification, the caregiver will need to accept responsibility for handling the problem, and will then be asked to respond to the voice message by pressing the "1" key on the telephone. If the caregiver does not respond by pressing the "1" key on the telephone, the MD.2 will continue to call up to four caregivers, (4 tries per caregiver). If it fails to contact any caregivers, the MD.2 then calls the Support Center.

### ***The Support Center***

The Support Center provides 24 hour monitoring, as well as programming and scheduling medication delivery times into the MD.2. Should a medication delivery be missed and the MD.2 is unable to reach any of the caregivers, the Support Center staff will attempt to make additional contacts.

If it is being monitored the MD.2 reports on a daily basis to the Support Center on a toll free number using the user's telephone line. Medication delivery, machine status, and other information is reported to the Support Center. Should the MD.2 not check in at its scheduled time, the Support Center staff will attempt to notify the caregivers.

## **▲WARNING**

### ***The Caregiver***

The most important element of the success of the MD.2 is the caregiver. *The correct filling of medication cups and proper loading of the MD.2 in a timely manner is the responsibility of the caregiver.* Any problems reported by the MD.2, such as missed medications, machine empty, etc., are also the responsibility of the caregiver to rectify.

### **3. List of Equipment**

The MD.2 comes complete with the following items as standard equipment:

- MD.2 dispenser unit
- AC Power adapter
- 12 ft. Telephone hook-up cable
- Battery Pack w/ 8 C cell batteries
- Keys for Door Lock (two plastic)
- User's Manual
- Warranty Card
- First months supply of dispense cups with lids, quantity 100
- Medication cup loading tray

Optional equipment and services available for the MD.2 include:

- Extended Support Center services
- Deluxe Medication Cup Loading Aide Station
- Travel Cord Adapter (this plugs into the power source or cigarette lighter of your auto)

Replacement items available from IMD for the MD.2 include:

- Medication cups and lids, 200 per package, order P/N IMD-5-753
- Client Information and Medication Dosage Worksheets, order P/N IMD-8-004

Replacement items commercially available for the MD.2 include:

- C cell batteries: IMD recommends use of high quality alkaline batteries.

## 4. Your New MD.2

### *Physical Description of Dispensing System*

The MD.2 is 13" x 12" x 14" tall. It has an audio speaker, an LCD message screen, a high intensity red alert light, and a dispense button (all located on the front of the unit). A power cord connector, telephone line connections and On/Off slide switch are located in the rear of the unit. A 12 function keypad is located on the right side of the machine, behind the locked door. Also located behind the door are the medication cup cylinders, the missed medication storage area, and access to the battery pack. The specific location of each item can be seen in Figure 4.1.

FIGURE 4.1 VIEW OF UNIT

#### Locked Front View

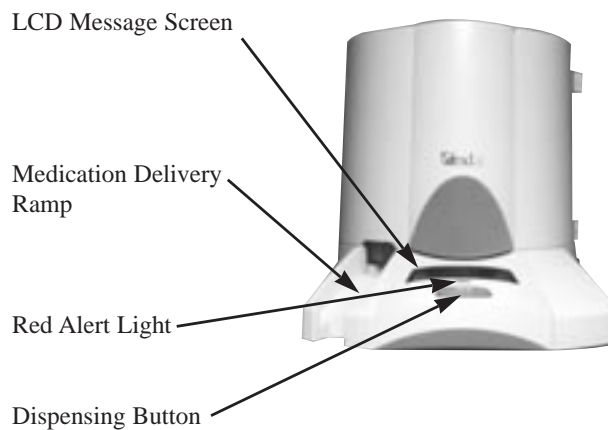

#### Unlocked Side View

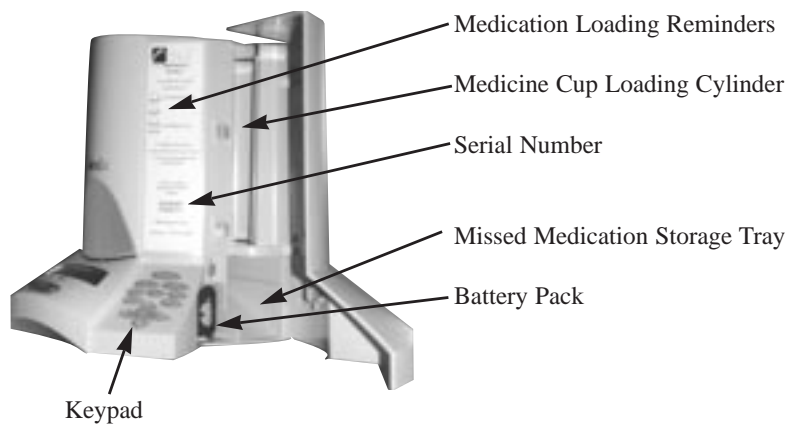

**▲ WARNING** Always keep locked with the key stored in a safe place.

## Keypad Overview

With the 12 function keypad you direct the scheduling and loading of medications into the machine. The keypad also directs a number of other functions that will be discussed in later sections. Figure 4.2 depicts the keypad layout of the MD.2.

Figure 4.2 Keypad Layout



### ***Run***

This key will return the MD.2 to normal operation after you have used other keypad features.

### ***Load***

This key is used to load medication cups into the unit (after they have been appropriately filled by the caregiver). After pressing this key, the medication cup cylinders move to the correct position and the machine voices, "Cups must be loaded upside down". This allows the caregiver to begin loading the machine with cups. The display on the front of the machine and the MD.2 voice instructs the caregiver as to how many cups to load into the unit for each day, after the dosing schedule has been programmed into the MD.2.

### ***Setup***

This function allows you to set the time, adjust display brightness and speaker volume. These functions are initially set by the Support Center when the medication schedule is programmed.

### ***Help***

This key provides information on use of the system. It also provides access to the Unload and Purge medication cup functions.

### ***Status***

This key provides multiple functions:

1. Information on missed doses (if any).
2. How many days of medication remain until the MD.2 needs to be reloaded.
3. If the battery pack needs to be replaced.

### ***Early Dose***

This key allows the caregiver to take medication cups out of the MD.2 ahead of schedule. This function is used when the user is planning to be away from the MD.2 for any dosing period. Multiple medication cups can be taken out sequentially when the user is away from the MD.2 from hours to days. This does not disrupt the ongoing scheduled functioning of the machine. The caregiver assumes responsibility for delivering medication cups taken from the unit.

### ***Schedule***

This key allows the Support Center to program your MD.2 with your medication schedule.

### ***OK***

This key acts as an "Accept" or "Enter" key. When a selection field is flashing on the display,  pressing this key will accept, verify or "okay" the flashing selection. An example of a selection can be seen in the following display (BOLD text represents a flashing field on the screen)

## Example

>	>	S e t u p	O p t i o n s
		T i m e	L C D V o l Q u i t

The **OK** key also is used to save a setting on the screen. In the following example, pressing the **OK** key will set the time.

Save screen setting example:

M o n / D a y	H r	M i n	Y e a r
0 1 / 0 2	1 2	: 5 6 A	1 9 9 9

***Left & Right Arrows***

The triangular buttons on either side of the OK key are the selection keys. Each time you press either key, the active field on the front display will move one position.

***Up & Down Arrows***

The triangular buttons above and below the OK key are the adjusting keys. Pressing the **Up** key causes the flashing value on the screen to go up one place or value. Pressing the **Down** key causes active flashing value on screen to go down one place or value. Depressing either of these keys continuously will cause the numbers to scroll rapidly in sequence.

***Unpacking and Preparing Your MD.2 for Use***

Once you have removed the MD.2 from its shipping container, please follow the steps outlined to set it up properly.

**▲WARNING**

**If your MD.2 has been stored or kept in a place that is cold (below 32°F/0°C) for longer than two or three hours please unpack your MD.2 and let it sit in a warm room for three to five hours before setting it up.**

**Do not locate in areas of high moisture (such as a bathroom.)**

- Place the MD.2 on a counter or stable tabletop near an electrical outlet and a telephone wall jack. This location should be in a living area that allows the user to hear the unit, see the display easily, as well as provide enough room to open the door when loading.
- Open the door of the unit by inserting the key into the lock and turning the key clockwise, gently pulling the door open when the key will no longer turn.

- c. Remove the foam packaging material from behind the MD.2 door. This piece of packaging foam protects the precise moving parts in the unit during shipping. *Failure to remove this packaging foam will cause unit to malfunction.*
- d. Connect the MD.2 to nearest telephone line outlet with the phone cable(s) provided. If a telephone must be disconnected from the wall jack, the telephone may be re-plugged into the convenient extension jack in the back of the MD.2. Refer to Figure 3 for location of the telephone connectors on the back of the MD.2.
- e. Make sure the MD.2 power switch is in the off position (refer to Figure 3). Plug the small end of the AC power adapter into the back of the MD.2. Plug the large end of the AC adapter into a wall outlet. Note: Make sure that the wall outlet is not a switched outlet (i.e. controlled by a wall switch somewhere in the room).
- f. Install the 8 C cell battery pack into the machine by first sliding the battery pack into the machine and then connecting the battery pack to the electrical connector in unit.
- g. Save packing box in the event of repair.

FIGURE 3 CONNECTOR PANEL LAYOUT

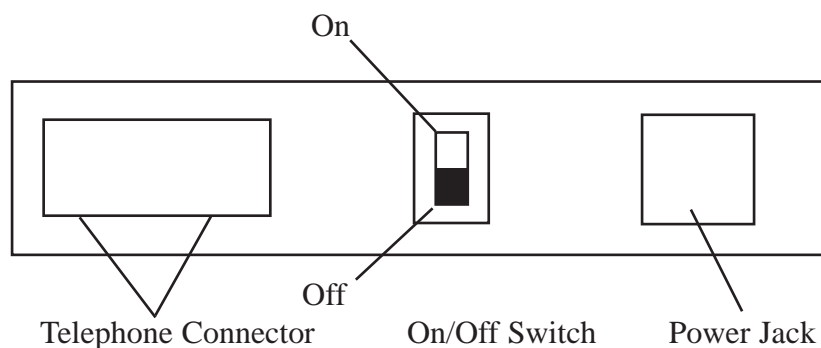

### **Powering Up the Unit**

When the MD.2 has been readied for use as outlined in the previous section, it is ready to put into service. Turn the unit on by pushing the slide switch at rear of unit to the On position. The display will first read:

```
S e l f   T e s t   U n d e r w a y
P l e a s e   W a i t
```

This self-test operation takes one to two minutes. Once the unit has successfully passed its self-test and has aligned its medication cup cylinders, the screen will read:

```
R e a d y   f o r   S e t u p
S y s t e m   O K       1 2 : 0 0 A
```

Additionally, the MD.2 voice will say "System OK, Ready for setup". A default time setting will be flashing in the lower right corner.

## 5. Setting Up the MD.2

### ***The process to set up your MD.2 includes:***

1. Installing the machine (p. 12 & 13)
2. Completing and submitting the worksheets (p. 14 & 15)
3. Downloading the schedule (p. 17)
4. Loading the MD.2 (p. 18-20)

### ***Information Sheets***

The MD.2 is programmed through your Customer Support Center. The setup is fast and easy. Prior to contacting your Customer Support Center, the following information sheets need to be completed: (These blank forms are located in the back of this user manual.)

1. The User and Caregiver Information (2 pages)
2. The User Medication Worksheet (1 page)

This information can be mailed, faxed or called in to your Customer Support Center:

Once the forms are received (minutes with a fax, 5-7 days via mail) or called in, the MD.2 can be set up.

### ***User and Caregiver Information Form***

These forms are located in the back of this manual. For your convenience, sample forms with user information examples, have also been provided. Please refer to the example forms as you fill in your worksheets.

*The User and Caregiver Information form asks basic questions about who will be getting their medication from the MD.2 (the User) and who is responsible for loading the medications and responding to alerts (the Caregivers). Caregivers should be individuals who are familiar with the User, the operation of the MD.2, and who are able to check on the user and the MD.2 when there is a notification of a missed dose or other problem.*

1. **Serial Number:** The serial number of your MD.2 is located on the label inside the locked door.

2. **User Information:** The name, address, time zone, phone (including area code), etc., of the individual who will be getting their medications from the MD.2.
3. **Caregiver Information:** A caregiver is a spouse, relative, neighbor, friend, visiting nurse agency or a home health agency. The caregiver is responsible for the proper loading of the MD.2 and responding to any calls made by the MD.2 to the caregivers. The order in which caregivers (1, 2, 3, or 4) are listed is the same order the MD.2 will use to notify caregivers when a response is needed. Please enter the exact caregiver phone number as dialed from the user's home. Important: In the event of a missed dose or problem, the initial calls to caregivers are made directly from the MD.2 unit. From the user's home, is it a long distance call to notify the caregiver? Please circle "Y" for Yes or "N" for No.

*Fax and Email:* This information is helpful and allows IMD to send you immediate verification that your MD.2 has been programmed. If you do not have fax or email access, please enter "none". If you do not have four caregivers simply fill in "none" in the caregiver space. There must be one caregiver listed.

4. **Recordkeeping and Documentation:** The information requested on the second page of this worksheet assists IMD with billing, record-keeping and documentation. It will only be used by IMD and will not be published.

The information requested on the second page of this form is to clearly identify who is your Customer Support Center and how do you reach them. Please make sure that your sales or installation person provides you with the information necessary to complete this section.

5. **Signature and Date:** Sign and date the form. Proceed to the User Medication Worksheet.

### *User Medication Worksheet*

This form is located in the back of this manual. For your convenience, a sample form with a user medication schedule, has also been provided. Please refer to the example forms as you fill in your worksheet.

### **▲ WARNING**

The *User Medication Worksheet* asks for the dosing times, medications and messages of the User. These are the actual instructions that will be programmed into the MD.2. **IT IS CRITICAL THAT THIS INFORMATION IS ACCURATE!!!** You will find the form and an example in the Appendix B.

1. Complete the *User Name* and *Serial Number* for your MD.2. The serial number is located on the label inside the locked door of the unit.
2. The MD.2 is programmed according to the information that you provide. If the information is the same for every day of the week, you need only to fill in Sunday information and write "same" in the remaining days of the week. If you want to vary your schedule, you will need to write in exact information for each day of the week. This form will also be used as a cup loading guide.
  - A. *Medications*: For each dosing time, write in the medications you take in the large box. You may also include insulin or inhaler time, patch application time and patch removal time.
  - B. *Dosing Time*. For each dosing period, write in the exact time of day you would like to have these medications dispensed.
  - C. *Messages*: Look at each prescription container and identify any specific instructions that are labeled for each prescribed medication. There can only be one message with each dosing or message period. Match any special label instructions with one of the messages listed on the Message List located in the back of this manual in Appendix A. Write in the message number under the correct medication. Make sure you fill in all rows.
  - D. *Message Only*: If you wish to have a reminder only to take your inhalant, eye drops, medication patch or injectable, etc. include the time you wish to be reminded in your medication schedule along with the appropriate message from the Appendix list. In the medication space, write "REMINDER ONLY".

When both forms are complete the information can be mailed, faxed or called in to your Customer Support Center.

### Setting up the MD.2

Table 5-1 describes the way that message types will be displayed during the set-up and programming of your MD.2.

Table 5-1.

Display Messages	<b>Text</b> represents flashing text on display screen <b><i>Text</i></b> represents display heading
Keys	<b>Text</b> represents actual keys to be pressed to perform described operation

Programming References

- Step 1. Call the your Customer Support Center
- Step 2. Tell the operator the user name and the serial number of the MD.2.
- Step 3. Instruct the Support Center that you are ready to have your MD.2 programmed.

After all information has been received and reviewed with the Support Center operator, the operator will instruct you to hang up the telephone and start the setup operation by pressing the **Schedule** key. The display will read:

```

M e d i c a t i o n   S c h e d u l i n g
S u p p o r t   C e n t e r           O t h e r

```

Support Center should be blinking. Press the OK key. The display will read:

```

O u t s i d e   L i n e   A c c e s s
D i r e c t   D i a l           P r e f i x   -

```

**Direct Dial** should be flashing. Press the **OK** key. You will first hear the dial tone, then the electronic dialing, followed by a modem "squeal/static" tone. At this same time, you will also see the following message in the display:

```

C a l l i n g   S u p p o r t   C e n t e r
P l e a s e   W a i t

```

If this is the first time the machine is being programmed, the following temporary message will appear on the screen. This should last about three seconds.

```

Y o u   W i l l   N o w   H a v e   t o
L o a d / C h e c k   M e d s   i n   U n i t

```

When the programming is successfully completed, the unit display will read:

```

U n i t   E m p t y   R e a d y   t o   L o a d
1 0 / 0 6   S y s   O K           1 1 : 2 6 A

```

(Note: The above is an example, you will see the correct time and date on your screen)

**If your MD.2 does not display the correct time, date or message, please call the Support Center immediately for assistance.**

## 6. Loading the MD.2

Organizing the medication, assigning dose times and determining what medications go into each cup is the responsibility of you, your caregiver and/or your health care provider. **It is not the responsibility of IMD.** A simple medication fill aid is included with your MD.2. This plastic coated tray is prepunched with 42 cup holes (a maximum of six doses per day/ 7 days per week) which will help organize the medication cups as you are filling them. **Never load nitroglycerin into the MD.2. Liquids, inhalants, patches and injectables cannot be dispensed through the medication cups or through the MD.2 machine.** However, reminder messages to use this type of medication can be included in the medication schedule. Pill or capsule medication is loaded into disposable, FDA and USDA approved 1 oz. plastic cups and lids. Only use cups and lids provided by IMD. Others will cause the MD.2 to jam.

**Before loading the MD.2 determine the maximum number of days of medication that is available.**

**For example:**

- 20 days supply of Lasix**
- 15 days supply of Atenolol**
- 18 days supply of Vitamin E**

**Using the example above, you can only load 15 complete days of medication. Set up 15 days of dosing cups and fill them appropriately.**

**Try to get all of your medication refills on the same 30 day cycle. Taking the enclosed letter to your pharmacist may be helpful. It may take a couple of weeks to get them all on the same schedule but then you can load the MD.2 most efficiently. This will also save trips to the pharmacy!**

**When you load the MD.2 for the first time only load it for a week. This will allow you to be sure that the times and messages that you have chosen work for you. If everything is great after a week then reload the MD.2 for the maximum number of days possible. If something needs to be changed (a dosing time or a message) then just call your Customer Support Center and make the change. You will then have to download your new information and reload the MD.2.**

### Load Capacities

The MD.2 can hold from 1 to 40 days worth of medication cups, depending upon the delivery schedule selected. The table below summarizes the delivery schedule / capacity relationship.

Delivery Rate	Capacity, # Days
1 delivery /day	40 days
2 delivery /day	30 days
3 delivery /day	20 days
4 to 6 delivery /day	10 days

## Procedure for Filling Medication Cups

**▲ WARNING** Extreme care must be used in the preparation, filling, and loading of the cups into the MD.2. Medication and doctor’s orders must be followed exactly. Load only capsules or pills into the medication cups. **NO LIQUIDS, INHALANTS, PATCHES, INJECTABLES OR NITROGLYCERIN CAN BE DISPENSED THROUGH THIS MACHINE!!!** **However, reminder messages to use this type of medication can be included in the medication schedule.**

Procedure for filling dose cups:

1. Verify that the User Medication Worksheet, messages and schedule are accurate and complete.
2. Place the cup-filling tray on a stable surface so that it is easily filled and checked.
3. Install the empty cups in the holes in the tray with one vertical row of up to 6 doses for each day of the week. If there are to be less than 6 doses for a given day leave the holes empty.
4. Once all cups have been filled, snap the lids on the cups securely. **Lids must be pressed completely and securely on the cups, otherwise, the MD.2 may jam.**

Once the cups have been filled with medication, the caregiver is responsible for loading them into the MD.2. The loading port is located to the right and above the keypad (refer to Figure 4.1). **Accuracy in loading the unit is critical.** Double-check each cup before inserting it into the machine. Check for the right medication in the right dose cup, as well as making sure the lid of the dose cup is securely and completely closed. **As the machine is loaded, all cups must be placed with their removable cover facing down.** Failure to insert cups in the unit in the proper upside down position will result in a malfunction of the unit (cups will jam in the machine). The MD.2 delivers medication cups from the bottom of the stack. The first cup loaded is the first cup delivered and corresponds with Dose 1 in schedule, the second cup loaded corresponds to the 2nd cup delivered and Dose 2 of the schedule, etc.

Throughout the loading process, the MD.2 will inform you by a voice message and through the display feature, exactly how many medication cups to place in the machine. The MD.2 voice will instruct you as to the number of cups you will need to load and the display will indicate the number of cups, the day of the week and the calendar date that is being loaded, as noted in the following example:

L	o	a	d		6		C	u	p	s		S	a	t		8	/	2		1	
P	r	e	s	s		<b>O</b>	<b>K</b>		K	e	y		W	h	e	n		D	o	n	e

For each day loaded, verify the correct number of medication cups in the machine by pressing the **OK** key. **It is critical that you follow the directions on the screen.**

### Loading an Empty MD.2

When you know there is a doctor's appointment scheduled only load the MD.2 for two or three days after the appointment. That way, if your doctor changes your medication, there will be fewer cups to change.

If the MD.2 is empty or if this is the initial load, loading the unit will start from the current day's schedule. The MD.2 will keep track of, and skip medication delivery periods that have already passed. Therefore, for the first day, the number of cups instructed to be loaded could be less than the total number of cups to be delivered for a full day. For example, say today is Friday, 8/20, and 4 deliveries are scheduled for 8AM, 12PM, 4PM, and 8PM, and you are loading the MD.2 at 2PM. From the above schedule, the user should have already taken the 1st two doses of the day, so the MD.2 requires that you load 2 medication cups for today. The MD.2 will voice, "Please load two medicine cups," and the following information will display on the screen:

L	o	a	d		2		C	u	p	s		F	r	i		8	/	2		0	
P	r	e	s	s		<b>O</b>	<b>K</b>		k	e	y		W	h	e	n		D	o	n	e

As a further example, let us assume that you are loading the unit at 4PM, the 3rd delivery time. The MD.2 will voice, "Please load one medicine cup," and the display will read:

L	o	a	d		1		C	u	p	s		F	r	i		8	/	2		0	
P	r	e	s	s		<b>O</b>	<b>K</b>		k	e	y		W	h	e	n		D	o	n	e

The MD.2 is asking you to load just one cup (for the 8PM delivery). It assumes that since you are loading at or after a delivery time, you are there to physically give the medication to your user.

### Initial Loading of Daily Medications

To start loading the MD.2 with medication cups, press the **Load** function key. If the unit has not been completely set up (i.e. clock needs to be set and/ or a schedule needs to be programmed) you will be reminded (via a display message) what must still be set up in order to load. Refer to Section 5, Setting Up the Unit, for further direction. When all setups are complete, the screen will display:

M	e	d	i	c	i	n	e		C	u	p	s		i	n		M	o	t	i	o	n
P	l	e	a	s	e		W	a	i	t												

The MD.2 will take up to two minutes to position the medication cup cylinders. Once the unit has finished positioning, the MD.2 will voice, "Please load six medicine cups," and the display will read:

L	o	a	d		6		C	u	p	s		S	a	t		8	/	2		1	
P	r	e	s	s		<b>O</b>	<b>K</b>		k	e	y		W	h	e	n		D	o	n	e

In the above example, six cups are to be loaded for Saturday August 21. Cups must go into the unit with the lid facing down (i.e. cup upside down). The first delivery of the day goes in first, last delivery of the day in last. When all cups requested on the screen have been inserted into the unit, press the **OK** key. This informs the MD.2 that you have loaded one day of medication. The display will now read:

```
C o n t i n u e   L o a d i n g   M e d s   ?
C o n t i n u e   Q u i t
```

If you have more days of medication to load, press **OK** while the *Continue* field is active (flashing). ***Unless prompted by the MD.2, do not load a partial day of medication!!***

The MD.2 will reposition its medication cup cylinders for the next day and begin the daily load sequence again. When you are finished loading the MD.2, use the right or left arrow key until **Quit** is flashing. Press **OK**. The display will return to the normal operating display:

```
N e x t   D o s e :   0 2   H r   2 3   M i n
0 8 / 2 1   S y s t e m   O K   0 8   : 5 9 A
```

You have successfully loaded medication into the MD.2. The unit is now in its normal delivery mode of operation.

### Re- Loading Daily Medications

When you know there is a doctor's appointment scheduled only load the MD.2 for two or three days after the appointment. That way, if your doctor changes your medication, there will be fewer cups to change.

Press the Load function key. The screen will display:

```
S e l e c t   L o a d i n g   M o d e
L o a d   A l t e r   M e d s   R e v i e w
```

Press the **OK** key, while the *Load* field is flashing. The display will read:

```
M e d i c i n e   C u p s   i n   M o t i o n
P l e a s e   W a i t
```

The MD.2 may take up to 2 minutes to position its medication cup cylinders. The MD.2 will voice, "Please load six medicine cups," and the display will read:

```
L o a d   6   C u p s           S a t       8 / 2 1
P r e s s   O K   k e y   W h e n   D o n e
```

The MD.2 informs you exactly how many cups to load into the machine, as well as the day of the week and the calendar date that the medications will be delivered. To load properly, cups must go into the unit with the removable lid down (i.e. cup upside down). The first delivery of the day goes in first, last delivery of the day in last. When cups have been inserted in to the unit as prompted on the display, press the **OK** key. This tells the MD.2 that you have loaded one day worth of medication per the directions on the screen. The display will now read:

C	o	n	t	i	n	u	e	L	o	a	d	i	n	g	M	e	d	s	?	
C	o	n	t	i	n	u	e	Q	u	i	t									

If you have more medication to load, press **OK** while the Continue field is flashing. ***Unless prompted by the MD.2, do not load a partial day of medication!!*** The MD.2 will reposition the medication cup cylinders for the next day and begin the daily load sequence again (repeat steps outlined above).

When you are finished loading the MD.2, use the **Right** or **Left** arrow key until Quit is flashing, the display will return to the normal operating display:

N	e	x	t	D	o	s	e	:	0	2	H	r	2	3	M	i	n	
0	8	/	2	1	S	y	s	t	e	m	O	K	0	8	:	5	9	A

You have successfully loaded medication into the MD.2. The unit is now in its normal delivery mode of operation.

## 7. Adjusting Your MD.2

### Setup Key

Time, display brightness, and volume are adjusted with this key. To start, press the Setup key. The display will read:

```

      S e t u p   O p t i o n s
< <   T i m e   L C D   V o l   Q u i t

```

### Time

The Customer Support Center will set the time, time zone and Daylight Savings Time according to your region. If, after setup, the time is incorrect call the Support Center for assistance.

```

      S e t u p   O p t i o n s
< <   T i m e   L C D   V o l   Q u i t

```

### LCD (Screen Brightness)

From the main setup screen, use the **Right** or **Left** arrow key until the “**LCD**” field flashes on the display screen. Press **OK**. The display will read:

```

      C o n t r a s t   A d j u s t m e n t
U p / D n : A d j u s t           O K : Q u i t

```

When the **Up** arrow key is pressed, the higher the contrast will get. If less contrast is desired press the **Down** arrow key. The more times the Down arrow is pressed the weaker the contrast will be. When you are finished, press **OK**. The display will return to the following setup screen:

```

      S e t u p   O p t i o n s
< <   T i m e   L C D   V o l   Q u i t

```

### Vol (Volume Setting)

From the main setup screen, use the **Right** or **Left** arrow key until the Vol field flashes on the display screen. Press **OK**. The display will read:

```

      V o l u m e   A d j u s t m e n t
U p / D n : A d j u s t           O K : Q u i t

```

Press the **Up** arrow key to raise the volume, press the **Down** arrow key to lower the volume. NOTE: Each time you press the **UP** or **DOWN** arrow key, the unit will voice "Thank You". There are only three volume setting to choose from, low, medium (default setting) and high. When you have set the volume, press **OK**. The display will return to the main setup screen. Use the right arrow key until **Quit** is flashing.

```

      S e t u p   O p t i o n s
< <   T i m e   L C D   V o l   Q u i t

```

## 8. Operating the MD.2

### ***Normal Operating Mode***

The MD.2 begins its normal operation after loading the unit. Once in normal operating mode you will see one of five different screen types displayed. They are:

#### 1. *In Between Deliveries Screen:*

N	e	x	t	D	o	s	e	:	0	1	H	r	1	7	M	i	n	
1	0	/	1	4	S	y	s	t	e	m	O	K	1	0	:	1	3	A

The time until the next dose is displayed on the top line. Today's date is displayed in the lower left hand corner of the screen. Current time is displayed on the low right hand corner of the screen. System status field is displayed on the center of the lower line.

#### 2. *Screen with flashing "System OK":*

N	e	x	t	D	o	s	e	:	0	1	H	r	1	7	M	i	n	
1	0	/	1	4	S	y	s	t	e	m	O	K	1	0	:	1	3	A

The flashing field indicates that the user has missed one or more doses of medication. Missed dose status can be determined through the Status key on the keypad. Notification of caregivers is attempted when a dose is missed.

#### 3. *Delivery Message:*

T	i	m	e	f	o	r	Y	o	u	r	M	e	d	i	c	a	t	i	o	n
P	l	e	a	s	e	U	s	e	B	u	t	t	o	n	1	2	:	5	9	A

The time of day will remain along with Time for Your Medication Please Use Button message on the screen. Press the large delivery button on the front of the unit. The display message will also be voiced by the MD.2 once per minute. A bright red light will flash. It is time for the user to take their medication. The MD.2 will continue in this mode for up to 45 minutes. If the user has not pressed the delivery button during this time, the MD.2 will add loud beeps to the voiced message. It will continue this operation for up to an additional 45 minutes. If the user has still failed to get their medication, the MD.2 will terminate this display and mode, place the missed dose into the missed dose storage bin, and will attempt caregiver notification.

4. *End of Day Message:*

N	M	M	T	O	O	M	E	E	D	I	C	I	N	E	T	O	D	A	Y
1	0	/	1	4		G	O	O		D	A	Y		1	0	:	5	9	P

No more medication is scheduled for delivery today. Time of day and the current day's date are still displayed continuously.

5. *Empty Message:*

U	N	I	T	E	M	P	T	R	E	A	D	Y	T	O	L	O	A	D			
1	0	/	1	4		S	Y	S		T	E	M	O	K		1	2	:	5	9	A

The unit has run out of medication. Time of day and today's date are still displayed continuously. Caregiver notification will be attempted when there is no more medication to be dispensed.

## 9. Additional Features

Along with its normal medication delivery the MD.2 has several helpful features. These features include:

1. “Early Dose” delivery capability
2. “Status” capability
3. Reviewing medication

### *Early Dose Feature*

The MD.2 is equipped with an early dose feature that allows you to take medication cups out of the unit ahead of schedule. This allows the user to be away for a few hours / days / etc. You may remove as many “early doses” as needed. To begin the operation, unlock the door and press the **Early Dose** button. The display will read:

R	e	a	d	y		f	o	r		E	a	r	l	y		D	o	s	e	?
Y	e	s								C	a	n	c	e	l					

The **Yes** field will be flashing. Press **OK**. The display will read:

F	e	t	c	h	i	n	g		M	e	d	s		S	c	h	e	d	u	l	e	d	
F	o	r				1	2	:	3	0	P			W	e	d			1	0	/	1	4

The MD.2 will display the scheduled delivery time for the medications you have just requested. Your medication will be delivered within two minutes. Once the medication cup has been delivered, the display will return to its normal operating mode. If you wish to take another dose from the MD.2, press the **Early Dose** button again. Each time you press the Early Dose button, one medication cup and or message will be dispensed and the MD.2 will return to normal operating mode:

If you have a “message only” dosing period within the times you wish to retrieve early doses the MD.2 will voice your scheduled message when you get to that dosing period. To obtain medications scheduled after the “message only” period press the “Early Dose” button again.

N	e	x	t		D	o	s	e	:		0	4		H	r		1	7		M	i	n
1	0	/	1	4		S	y	s	t	e	m		O	K		1	1	:	1	3	A	

### *Status Function*

The status function provides operational and missed dose information. The MD.2 shows the last 4 missed doses. The Status function also provides the caregiver with battery status and how many days are remaining until the machine is empty.

When the status field on the screen is flashing (i.e. **System OK** flashing), your user has missed one or more medication deliveries. To ask the MD.2 current missed dose status, press the **Status** key. The display will read:

R	e	m	o	v	e		M	i	s	s	e	d		D	o	s	e		C	u	p	s
P	r	e	s	s		O	K		K	e	y		W	h	e	n		D	o	n	e	

You are being instructed to remove all missed dose cups from the missed cup tray (behind the keypad) and then press **OK**. The display will provide information on the doses missed, including the date and time of the missed dose. In the example below, the first dose that was missed was on 8/21 at 11:45 AM.

T o t a l	D o s e s	M i s s e d	2
D o s e	1	0 8 / 2 1	1 1 : 4 5 A

Use the **Up** or **Down** arrow key to scroll through the missed dose number (flashing 1 field on screen). The time the dose was missed, as well as the date missed will appear on the screen. Once you are done reading the missed delivery information, press the **Run** key to return to normal operations. Once you press **Run**, the MD.2 logs any future missed doses.

If the status field on the normal screen is not flashing, pressing the **Status** key will display the following message on the screen:

#	D a y s	U n t i l	E m p t y :	1 2
B a t t e r y :				O K

The battery status will be either **OK** or **Replace**. A reading of “0 days until empty” indicates the MD.2 is empty. This message will remain on the screen for approximately 5 seconds. The unit will automatically return to normal operations after the 5 seconds.

### **Reviewing Medication**

The number of medication cups in the MD.2 can be checked at any time by using the Review function. To use the Review function, press the **Load** key. The display will read:

S e l e c t	L o a d i n g	M o d e
L o a d		<b>R e v i e w</b>

Use the Left or Right arrow keys until the **Review** field is flashing. Press the **OK** key. The display will read:

M e d i c i n e	C u p s	i n	M o t i o n
P l e a s e	W a i t		

The MD.2 will take up to two minutes to position its medication cup cylinders. The display will read:

C h e c k	3	C u p s	S a t	8 / 2 1
C o n t i n u e	Q u i t	C u p s	1 - 3	

The MD.2 informs the caregiver how many cups should be loaded in the unit for each day. Medication cups are visible to the caregiver in the medication cup cylinders. In this example, 3 cups are loaded for Saturday August 21. *Note: To accommodate multiple days there may be instances when there are more cups visible in the medication cup cylinders than the MD.2 reports on the screen.*

If the user has 3 or less dosing periods per day there may be multiple calendar days of medication stacked in each cylinder. In this example, when the screen first says “Check Cup 1-3” it is referring to the bottom 3 cups in the stack. If the Review function is used to check all of the medication cups the MD.2 may cycle back to this cylinder for another day’s medication and the screen will say “Check Cup 4-6”.

The lower right corner of the display screen will indicate which cups go with the displayed date. The cups are numbered as in the example below. The cup at the bottom of the tube is number 1, the next one up is number 2, etc. through number 6.

If there are 4 or more dosing periods per day there will be no more than one calendar date per medication cylinder.

Figure 4.3 Example of Multiple Days Medication Cups in Medication Cup Cylinders

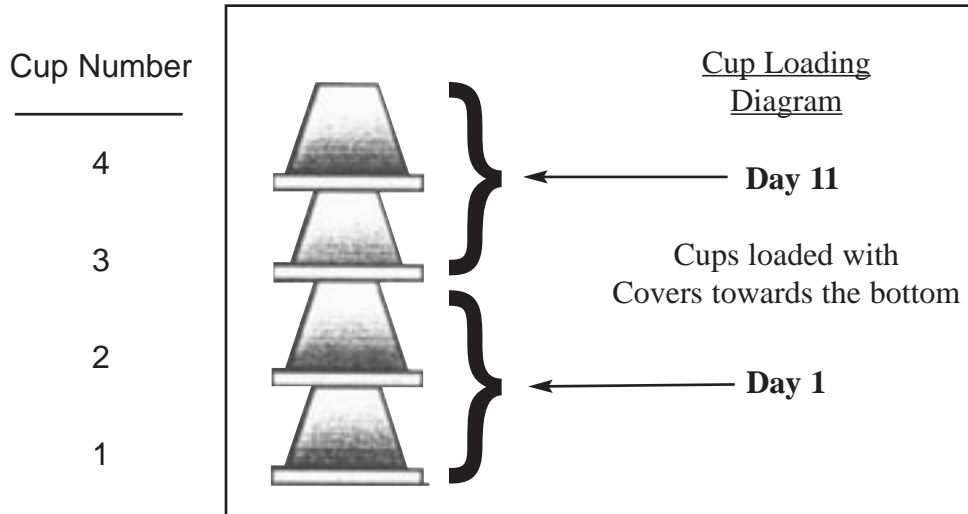

Once you have verified that the medication cups are loaded properly, press the OK key. The display will read:

```

M e d i c i n e   C u p s   i n   M o t i o n
P l e a s e   W a i t
    
```

The MD.2 is positioning its cylinders to the next day’s medications. The display will read:

```

C h e c k   3   C u p s           S u n   8 / 2 2
C o n t i n u e   Q u i t
    
```

Continue repeating the review steps until you are satisfied that all medications are loaded correctly. When you are finished, press the right arrow key until the Quit field is flashing. Press OK. The display will return to its normal operation:

N	e	x	t	D	o	s	e	:	0	2	H	r	2	3	M	i	n	
1	0	/	0	6	S	y	s	t	e	m	O	K	1	2	:	5	9	A

The MD.2 stops the Review function automatically when it reaches the end of the medications loaded.

## 10. Unloading Medication from the MD.2

You may need to remove medication cups from the MD.2 due to a medication change, a loading mistake, a jammed cup, or a power outage. The following functions allow you to remove medication cups:

1. *Unload* – Begins with the last day of medication loaded and works backward.
2. *Purge* – Allows the machine to be emptied without regard to a schedule

### *Unloading Medication Cups*

**Unload** begins with the last day of medication loaded in the MD.2 and works toward the present day's medication. The number of cups to be removed, as well as the date the medication was to be delivered, is displayed on the screen.

Press the **Help** key. The display will read:

S	p	e	c	i	a	l	H	e	l	p	F	u	n	c	t	i	o	n	s
U	n	l	o	a	d	P	u	r	g	e	S	/	N	Q	u	i	t		

Press the **OK** key, when Unload is flashing on your display. The display will read:

M	e	d	i	c	i	n	e	C	u	p	s	i	n	M	o	t	i	o	n
P	l	e	a	s	e	W	a	i	t										

The MD.2 is positioning its medication cup cylinder to the last day of loaded medications. When the unit is finished, the display will read:

U	n	l	o	a	d	3	C	u	p	s	S	u	n	8	/	2	2
P	r	e	s	s	<b>O</b> <b>K</b>	K	e	y	W	h	e	n	D	o	n	e	

You may now remove the number of cups displayed on the screen. When you are done with this day's medication, press the **OK** key. The display will read:

C	o	n	t	i	n	u	e	U	n	l	o	a	d	i	n	g	M	e	d	s	?
C	o	n	t	i	n	u	e	Q	u	i	t										

To continue unloading the medication cups, press the **OK** key while the *Continue* field is flashing. Repeat the “Unload” steps until you are finished. To exit the “*Unload*” function, press the Right arrow until the **Quit** field is flashing. Press the OK key. The display will return to the normal operating display:

N	e	x	t	D	o	s	e	:	0	2	H	r	2	3	M	i	n	
0	8	/	2	1	S	y	s	t	e	m	O	K	1	2	:	5	9	A

***Purge Function***

Purge allows the caregiver to empty the machine without regard to any schedule. For example, the user experiences a power outage and the batteries are completely drained. When power is restored, the MD.2 will power up but will have lost all knowledge of the dosage schedule and what medications were loaded. In this instance, all medication cups must be removed and the MD.2 must be reprogrammed and reloaded.

To start the Purge function, press the **Help** key. The display will read:

S	p	e	c	i	a	l	H	e	l	p	F	u	n	c	t	i	o	n	s
U	n	l	o	a	d	<b>P</b>	<b>u</b>	<b>r</b>	<b>g</b>	<b>e</b>	S	/	N	Q	u	i	t		

Use the right arrow key until **Purge** is flashing. Press the **OK** key. The display will read:

M	e	d	i	c	i	n	e	C	u	p	s	i	n	M	o	t	i	o	n
P	l	e	a	s	e	W	a	i	t										

The MD.2 is positioning its medication cup cylinders. This will take up to two minutes then the display will read:

R	e	m	o	v	e	A	l	l	C	u	p	s					
P	r	e	s	s	<b>O</b>	<b>K</b>	K	e	y	W	h	e	n	D	o	n	e

Remove all cups in medication cup cylinders and press OK key. The display will read:

C	o	n	t	i	n	u	e	U	n	l	o	a	d	i	n	g	M	e	d	s	?
<b>C</b>	<b>o</b>	<b>n</b>	<b>t</b>	<b>i</b>	<b>n</b>	<b>u</b>	<b>e</b>	Q	u	i	t										

Continue the Purge steps until you are finished unloading all medication cups from the machine. When you are finished, press the Right arrow until the **Quit** field is flashing. Press the **OK** key. The screen will display:

R	e	a	d	y	f	o	r	S	e	t	u	p						
1	0	/	0	6	<b>S</b>	<b>y</b>	<b>s</b>	<b>t</b>	<b>e</b>	<b>m</b>	<b>O</b>	<b>K</b>	1	1	:	2	6	A

The MD.2 is ready to be reprogrammed with the medication schedule (see Section 5) and reloaded with medication.

## 11. Telephone Functions and Features

The MD.2 shares the user telephone line to communicate with caregivers and the the Customer Support Center. It should not interfere in any way with normal user telephone operations. The MD.2 can only call out and will normally be on the line for less than 1 minute (3 minutes maximum).

Table 12.1 summarizes the calls that can be made to a caregiver. ***When the MD.2 unit connects to a caregiver there will be a 6-7 second delay before the MD.2 voices the message. Do not hang up! Wait for the MD.2 to deliver the message.***

Table 12.1 Caregiver Telephone Usage

Reason for Call	Call Made to:	Message
Missed Delivery (1-3)	Caregiver telephone number (1 of 4 numbers)	“This is the IMD medicine dispenser calling from <user name (spelled out)>, at <user ph #>. Your patient has missed their medication. Please press 1 key to acknowledge this message. Press the 2 key to repeat this message.” [1 key pressed by caregiver] “Thank you.”
Missed 4th Delivery	Caregiver telephone number	“This is the IMD medicine dispenser calling from <user name (spelled out)>, at <user ph #>. Four doses have been missed, the machine has been stopped. Please press 1 key to acknowledge this message. Press the 2 key to repeat this message.” <1 key pressed by caregiver> “Thank you.”
Machine Empty	Caregiver telephone number (1 of 4 numbers)	“This is the IMD medicine dispenser calling from <user name (spelled out)>, at <user ph #>. The machine is empty. Please press 1 key to acknowledge this message. Please press the 2 key repeat this message.” <1 key pressed by caregiver> “Thank you.”
AC Power Outage	Caregiver telephone number (1 of 4 numbers)	“This is the IMD medicine dispenser calling from <user name (spelled out)>, at <user ph #>. Your patient power is out. Please press 1 key to acknowledge this message. Press the 2 key to repeat this message.” <1 key pressed by caregiver> “Thank you.”
AC Power Restored	Caregiver telephone number (1 of 4 numbers)	“This is the IMD medicine dispenser calling from <user name (spelled out)>, at <user ph #>. Your patient power is on. Please press 1 key to acknowledge this message.” <1 key pressed by caregiver> “Thank you.”
Machine Error	Caregiver telephone number (1 of 4 numbers)	“This is the IMD medicine dispenser calling from <user name (spelled out)>, at <user ph #>. The MD.2 needs service. Please press 1 key to acknowledge this message. Press the 2 key to repeat this message.” <1 key pressed by caregiver> “Thank you.”
Machine Almost Empty  (Caregiver Aid Message)	Caregiver telephone number (First caregiver number only)	“This is the IMD medicine dispenser calling from <user name (spelled out)>, at <user ph #>. The MD.2 is almost empty. Please press 1 key to acknowledge this message.” Press the 2 key to repeat this message. <1 key pressed by caregiver> “Thank you.”
Batteries Low  (Caregiver Aid Message)	Caregiver telephone number (First caregiver number only)	“This is the IMD medicine dispenser calling from <user name (spelled out)>, at <user ph #>. The MD.2 batteries need to be replaced. Please press 1 key to acknowledge this message. Press the 2 key to repeat this message” [1 key pressed by caregiver] “Thank you.”

The MD.2 attempts to call up to 4 different caregiver telephone numbers. It will play back a pre-recorded message describing why it is calling. Caregivers must press the 1 key on their telephone (when asked to do so) to acknowledge receipt of message. When the MD.2 "hears" the 1 key, it will know a caregiver (as opposed to an answering machine or voice mail) has heard and understood the message. ***NOTE: The MD.2 will not leave a complete message on an answering machine or in voice mail. It will assume the caregiver cannot respond to the message and will attempt three additional calls. Also note that the caregiver must be using a touch tone telephone for the MD.2 to "hear" the 1 key.*** If the first caregiver has not responded after four attempts, the MD.2 automatically calls the next caregiver number on the list. The sequence continues until a caregiver responds by pressing the 1 key.

## 12. Trouble-shooting

Your MD.2 will provide years of trouble free operation when properly used and cared for. No adjustments or periodic service is needed by your MD.2. There are no serviceable parts or repairs that can be made by the user, so any service must be performed by factory trained technicians. Should your unit fail to operate properly, please call your Customer Support Center to coordinate replacement or repair of your unit.

Your MD.2 has extensive built-in test capabilities. It monitors its own operations, reporting detected problems to both you (through messages on the display) and the Support Center. Problems are reported through trouble report messages. The MD.2 has two error messages, Machine Error and Machine Stopped.

### *Machine Error Message*

! M a c h i n e E r r o r !
0 9 / 2 7      S E R V I C E      1 2 : 1 5 p

The machine error message indicates a problem with the internal MD.2 mechanism. The most common reason for this message is a medication cup jammed in the machine. The MD.2 also uses indicator lights to help further pinpoint the error condition. Refer to Table 13.1.

Table 13.1 Indicator Light Error Meaning

<b>Indicator Light Flash Count</b>	<b>Error Detected</b>	<b>Probable Cause</b>	<b>Home Repairable</b>
2 Flashes	Electronic Failure	Equipment failure	Not home repairable
3 Flashes	Mechanical Failure, Medication Tube	Jammed cup	Possible home repair
4 Flashes	Mechanical Failure, Cup Delivery Failure	Jammed cup	Possible home repair
5 Flashes	Internal MODEM /Telephone Failure	Equipment failure	Not home repairable

A jammed cup is a problem you can fix at home. Cups inserted the wrong way (bottom of the cup facing up, the lid **MUST** be facing down) double cups or double lids, or the use of deformed or crushed cups, are the most common causes of a cup jam.

### **Removing Jammed Cups**

- Step 1. Turn the MD.2 off (use the power switch in back of unit, and unplug the unit from the wall outlet).
- Step 2. Open the door.

- Step 3. Examine the cups that are visible in the medication cup cylinders. If any cups are facing up (i.e. lids facing upward) then cups are loaded incorrectly. See the Manual Unloading Procedure.
- Step 4. With a light touch, GENTLY try to rotate the medication cup cylinder mechanism (accessible through the medication cup load position). DO NOT FORCE the mechanism. It normally turns with only a modest amount of effort. Try rotating the mechanism in both directions. If the medication cup cylinder mechanism doesn't turn properly, go to Step 5.
- Step 5. Reach up into the cup delivery ramp (located to the left of the dispense button), and GENTLY try to rotate the medication cup transport. DO NOT FORCE the mechanism. It normally turns with only a modest amount of effort. If the medication cup transport mechanism turns properly, rotate it until it is centered over the ramp delivery. A cup may come out as you do this. If a cup does come out, be sure to remove the medication and then discard the cup. DO NOT REUSE A CUP THAT HAS JAMMED. If the medication cup transport does not turn properly, see the Manual Unloading procedure.
- Step 6. Once you have successfully moved both the medication cup cylinder mechanism and the medication cup transport, turn the power on the MD.2 using the switch in back of the machine. You should see the mechanisms moving again. You must now reset the dosage schedule by calling the Support Center. After your medication schedule has been reprogrammed, you will need to reload the medication into the machine. Examine each cup carefully and throw away any damaged or bent cups or lids.

If your machine still has a "Machine Error" message, call the Support Center for further assistance.

### ***Machine Stopped Message***

M a c h i n e   S t o p p e d														
0	9	/	2	7	S y s t e m		O K		1	2	:	1	5	p

The machine stopped message appears when the MD.2 missed dose storage bin is full (user has missed 4 doses). All MD.2 normal operations stop until the storage bin is emptied. To empty the storage bin, perform the following:

Step 1. Open the door.

Step 2. Press the Status key on the keypad. The display will read:

R	e	m	o	v	e	M	i	s	s	e	d	D	o	s	e	C	u	p	s
P	r	e	s	s	O	K	K	e	y	W	h	e	n	D	o	n	e		

A medication cup will eject down the normal delivery ramp. This is the fourth medication cup missed by your user. The other three missed medication cups will slide onto the tabletop when you open the MD.2 door. When all the missed medication cups are removed, press the **OK** key. The MD.2 will then display details on the medication missed by your user ( see Section 7, for a description of this Status feature).

Step 3. Press the **Run** key after you have read the missed dose status information. If the MD.2 did not sit with it's missed dose bin full overnight, then it will continue as normal. There **MAY** be additional missed dose(s) (depending upon delivery schedule). Messages on the screen will inform you of this. If the MD.2 was allowed to sit with its missed dose storage bin full overnight or longer, then you will have to check and reload medication in the unit. **WARNING, DEPENDING UPON HOW LONG THE MD.2 WAS LEFT IN THE "MACHINE STOPPED" CONDITION, YOU MAY HAVE MEDICATION CUPS LEFT IN THE MEDICATION TUBES. CHECK VERY CAREFULLY AS YOU RELOAD THE UNIT!**

### **Manual Unloading When Medication Cup Cylinder Mechanism Turns Freely**

If the medication cup cylinder mechanism turns freely, turn on the unit and use the Purge feature to remove all medication cups from the machine (see Section 11 for directions on using the Purge feature). If you cannot access the Purge feature, open the door, then **GENTLY** rotate the cup cylinder mechanism until a tube of cups is aligned with the medication cup loading port. With your finger or a pencil, slide the cups up and out the top of the medication cup cylinders. Rotate the medication cup cylinders to the next position and repeat the removal of cups. You will need to check all ten cylinders and remove all cups.

### **Manual Unloading When Medication Cup Cylinder Mechanism Is Stuck**

Before you begin with the manual unloading procedure when the medication cup cylinder is stuck, you need to have the following hand tools available:

- # 1 Philips screw driver
- Small flat blade screw driver

If the MD.2 appears to have a medication cup stuck internally and you have been unable to free it up through the Machine Error Corrective Action Procedure, **OR** the MD.2 has otherwise broken or malfunctioned and you can not get the medication out of the unit in any other manner (such as lifting cups out through the medication cup cylinders), then and only then should you perform the following corrective action steps:

#### **Cover Removal Procedure**

Step 1. Turn the MD.2 off (use the power switch in back of unit, just unplugging the wall transformer will not do it). Unplug the AC adapter from the wall outlet.

Step 2. Unplug the AC power cord from the back of the unit.

- Step 3. You will be removing the cover from the unit. If there is not enough headroom to do this where the MD.2 is currently placed, move it to a suitable table or workspace.
- Step 4. Remove the door: Open the door and swing it all the way back and then lift upwards. The door will lift off its hinges. Place the door on a clean flat surface away from the MD.2
- Step 5. Remove the top cover: Gently pry off the round plug located on the top of the machine, using the flat blade screwdriver, prying it from the door side of the plug. With the Phillips screwdriver, unscrew the screw that holds the cover down (in the recess below the plug that was just removed). When the screw is loose, lift the cover straight up, over the medication cup cylinders of the MD.2. Place the cover on a clean flat surface away from the MD.2
- Step 6. With your fingers, slide all medication cups out of the medication cup cylinder mechanism. Also free any cups stuck in the medication cup transporter (4" disk to the left of the exposed speaker).
- Step 7. If you are disassembling the unit because of a jammed cup, GENTLY check for free movement of moving parts once cups are removed.

### **Re-assembling the Unit**

- Step 1. Place the cover back onto the unit. It is designed so it will only go on one way.
- Step 2. While holding the cover in place, put the screw back into position and tighten the screw only until it is hand tight. DO NOT OVERTIGHTEN as you could damage internal components and fasteners.
- Step 3. Snap the plug back into position on the top of the cover. Note that it is also designed to only go on one way.
- Step 4. Pick up the door and align the hinges with the door in the fully opened position. When both hinge pins are aligned, the door will slip into place.
- Step 5. If you successfully dislodged a cup from the unit, GENTLY move the medication cup cylinder mechanism to make sure it moves properly. DO NOT FORCE the mechanism. If the mechanism turns with a modest effort, you are ready to turn on the unit.. Follow the directions in Section 4 – "Unpacking and Preparing Your MD.2 for Use" to re-establish the power and telephone connections to the MD.2. You must reprogram (see Section 5) the MD.2 and reload the medication cups.

If your unit still does not operate properly, please call your Customer Support Center. They will arrange to ship a replacement unit to you right away.

## 13. Frequently Asked Questions

For your convenience, IMD has compiled a list of answers to your most frequently asked questions on the installation and operation of the MD.2. They have been arranged in categories, to make it easier for you to find answers quickly.

### *Installation Questions*

#### **Telephone Related Questions:**

- Q:** Do I need a special telephone line to use the MD.2?
- A:** No, the MD.2 plugs into your existing telephone line, just like an extension phone or answering machine.
- Q:** Will my MD.2 work with other special telephone equipment I have connected (telephone amplifier, Caller ID units, etc.)?
- A:** The MD.2 has been designed to be as compatible as possible with other telephone related equipment found in the home. If the MD.2 is connected directly to your telephone line you should experience no problems.

#### **General Questions**

- Q:** Where should I put the MD.2 in the home ?
- A:** The MD.2 should be located someplace where the alerts can be easily heard and seen. It should also be placed fairly near a wall outlet and a telephone outlet. IMD recommends the unit not be placed near a sink or in a bathroom where excessive moisture (baths/showers) could damage the MD.2, or the medications inside the MD.2

### *Operational Questions*

#### **Telephone Related Questions**

- Q:** Will the MD.2 cause me to miss any calls / interfere with my calls ?
- A:** The MD.2 only uses the telephone line when 1.) a dose is missed, 2.) machine needs service, 3.) it is checking in with the Support Center. None of these calls take more than a minute so your telephone line is not tied up for any significant length of time. If the MD.2 needs to make a call out, it first checks the telephone line to make sure it is not in use. If it is in use, it will try to call later.

- Q:** Will I have a higher telephone bill each month because of the MD.2?
- A:** All calls to the Customer Support Center are free. If caregivers are all local calls, then there should be no additional telephone costs.
- Q:** Will the call caregiver function work with my caregivers' pager/answering machine/etc.?
- A:** No. The MD.2 needs to contact the caregiver directly and expects a response (pressing the "1" key on the telephone) to know when a caregiver has taken responsibility for the alert (the reason the MD.2 called the caregiver). Pagers, answer machines, etc. will not be able to reply properly. The MD.2 will call the next caregiver in the list if it does not "hear" the proper response.

### **Power Related Questions**

- Q:** How much power does the MD.2 consume?
- A:** The MD.2 consumes less than 4 watts typically, and less than 10 watts when a medication cup is delivered. A typical night light draws about 8 watts.

### **Schedule /Setup Related Questions**

- Q:** How do I change the medication schedule?
- A:** Call the Customer Support Center and one of our trained operators will record the new schedule information. The Support Center will then reprogram the machine. See Section 5 for details on this operation. (You will have to have the MD.2 call the Support Center to download the changes.)
- Q:** How much time do I have to take my medications once the MD.2 starts its medication alerts?
- A:** The MD.2 sets the medication availability time based on your dosing schedule. It looks at each scheduled delivery time for the day and takes one-half the lapsed time to the next scheduled delivery or 90 minutes, whichever is shorter. See example below:

Scheduled Delivery	Time between Deliveries	Alert Time
8 AM		
	4 Hrs	90 Min
12 PM		
	6 Hrs	90 Min
6 PM		
	2 Hrs	60 Min
8 PM		90 Min

In the example above, the closest two delivery times are 2 hours apart, so the MD.2 will assign one hour (1/2 of 2 hours) as the medication alert time between the 6 pm and 8 pm dose. For other delivery times, in the example above, that are 3 or more hours apart, the alert time is 90 minutes.

**Q:** How closely can I schedule medication deliveries?

**A:** The MD.2 can deliver medication cups as close as 5 minutes apart. In general IMD does not recommend that you space any deliveries that close together, as this gives the user a very short medication availability time, or alert time.

**Q:** Can I have different delivery times for the weekend (or any day of the week)?

**A:** Yes, the MD.2 is fully capable of supporting a unique variety of schedules and doses per day for each day of the week.

**Q:** Can I schedule days where no medications are delivered?

**A:** No, there must be at least one, and no more than 6 deliveries for each day. If your schedule requires you to skip a day, you could deliver an empty cup (or a cup filled with a candy "treat") on days you do not take medication. This technique might also help your user stay in the habit of taking their medications.

## Loading Questions

**Q:** I went too far in the loading procedure and have run out of medications for the day the MD.2 is asking to be loaded for.

**A:** To remedy this problem just finish up the loading process knowing that you did not load medications for the last day. Next, press the **Help** key, followed by the **OK** key, to activate the **Unload** process. Follow directions on the screen and **Unload** the last day's worth of medications (the day where the error was made). **Quit** the **Unload** after removing the erroneous day(s) (by pressing the **OK** key when **Quit** is flashing on screen). For complete details, see Section 11.

- Q:** What should I do if I place cups in the machine the wrong way (cup side up)?
- A:** **You must fix this situation immediately.** The MD.2 is designed to work with the cups placed top side down (upside down) only. The unit will jam with the cups facing up. Use the Unload feature of the MD.2 to remove all cups from the MD.2. (See Section 11 for instructions.) Place cups back in the medication cup fill station so as not to get them confused when re-loading them. Once all cups are out, reload the machine in the usual manner with the cups upside down.
- Q:** How do I check that I loaded the MD.2 correctly?
- A:** The *Review* function allows you to check medication cups already loaded in the machine. (See Section 10.)
- Q:** My user has a new prescription to take. How do I add this new medication to the medication cups already loaded in the MD.2?
- A:** Use the Unload feature described in Section 11 to unload all of the cups in your machine. You may then add or change the medications in the cups and load as usual.

### General

- Q:** What happens if there is a power failure? Does my MD.2 lose all of its programming?
- A:** The MD.2 will run on a fresh battery pack for at least 12 hours. If you let the battery run low, you have not loaded the fresh battery pack, or your power outage lasted beyond the 12 hour limit, the machine could lose the programming information. When you have direct power, unload the medication cups following the Purge instructions in Section 10, then call the Support Center to reprogram your machine (See Section 5).
- Q:** *System OK* keeps flashing on the screen. What does that mean and how do I get it to stop blinking?
- A:** *System OK* flashing means that your user has missed 1 or more doses. To clear the flashing you must remove the missed medication cups and press the OK key. The screen will then display the number of missed doses. Use the Up or Down key to display the dates and times of missed doses. When you have reviewed them all press the Run key.

**Q:** How soon do I have to replace batteries once the **Batt Low** indication shows up on the screen (and /or when the MD.2 calls me to inform me of the low battery condition)?

**A:** Batteries should be replaced as soon as possible, when the **Batt Low** indicator comes on. When this displays, over 2/3rds of the battery energy has been used and the machine may not have enough battery power to dispense your next dose. (The MD.2 will run on a fully charged battery pack for approximately 12 hours if you had a power outage at your home.)

**Q:** My user is traveling for a few days, how do I get medications out of the MD.2? Should I turn the MD.2 off while they are away?

**A:** The MD.2 has an *Early Dose* feature which is specifically intended for this situation. You can use this feature to remove 1 dose to several days' worth of medications. See Section 10 for instructions on how to use this feature. The caregiver traveling with the user will need to assume responsibility for delivering medications on time to the user. Do not power off your MD.2, the MD.2 knows you have taken medication cups out early and knows when it should deliver the next dose. It will be ready and waiting when your user returns home.

**Q:** The screen on my MD.2 reads

Machine Error  
!Service!

What do I do?

**A:** Your MD.2 has experienced a situation that can only be resolved with human intervention. When the MD.2 is in this state, it flashes the red lights in a distinct pattern. This pattern indicates what is wrong. Refer to Section 13, Table 13.1 for specific details on how to interpret and correct the situation.

## 14. List of important phone numbers

For assistance with your MD.2, call your Customer Support Center toll free.

## 15. Regulatory Agency Information

### ***Telephone Connection Information***

The Federal Communications Commission (FCC) has established rules that permit the use of this device to be directly connected to the telephone network. The unit is provided with two standardized plugs and two standardized cables with jacks to be used to make this connection. Non standard cables/jacks should not be used. The FCC also requires that this unit not be used on party line or coin operated telephone lines.

### ***Telephone Company Information***

Should the telephone company request information about the devices connected to their telephone lines, the following information pertains to the IMD MD.2:

- |    |  |                       |
|----|--|-----------------------|
| A. | Telephone number Unit is connected to: | Your telephone number |
| B. | Ring Equivalence Number (REN):         | 0.7B                  |
| C. | USOC jack required:                    | RJ11C                 |
| D. | FCC Registration Number                | 6HYUSA-33790-MD-E     |

Items B, C, D can be found on the MD.2 product label applied to the base of the unit. In most areas, the sum of the RENs of all devices on the line should not exceed five (5.0). If too many devices are attached, they may not ring properly.

The telephone company also may make changes in its technical operations and procedures over time. If such changes affect the compatibility of, or use, of this device, the telephone company is required to give adequate notices of these changes.

### ***FCC Emissions Compliance Statement***

**Warning:** Changes or modifications to this unit not expressly approved by the party responsible for compliance could void user's authority to operate this equipment.

**NOTE:** This equipment has been tested and found to comply with the limits for a Class B digital device, pursuant to Part 15 of the FCC Rules. These limits are designed to provide reasonable protection against harmful interference in a residential installation. This equipment generates, uses, and can radiate radio frequency energy and, if not installed and used in accordance with the instructions, may cause harmful interference to radio communications. However, there is no guarantee that interference will not occur in a particular installation. If this equipment does cause harmful interference to radio or television reception, which can be determined by turning the equipment off and on, the user is encouraged to try to correct the interference by one or more of the following measures:

- Re-orient or relocate the receiving antenna.
- Increase the separation between the equipment and receiver.
- Connect the equipment into an outlet on a circuit different from that to which the receiver is connected.
- Consult the dealer or an experienced radio/TV technician for help.

### ***Canadian EMI Specification Compliance Statement***

This Class B digital apparatus meets all requirements of the Canadian Interference-Causing Equipment Regulations.

Cet appareil numérique de la classe B respecte toutes les exigences du Règlement sur le matériel brouilleur du Canada.

## **Appendix A. Medication Message List**

0. - No Message -
1. Time for your Insulin
2. Take meds with food
3. May cause drowsiness
4. No food with meds for 2 hrs
5. Take extra fluids with meds
6. Change Catapres Patch
7. Change Estrogen patch
8. Change Duragesic patch
9. Put on Nitro patch
10. Remove Nitro patch
11. Use Nasal spray
12. Use Mouth inhaler
13. Take on an empty stomach
14. No alcohol with meds
15. Don't drive with this med
16. Take meds with juice
17. Take meds with milk
18. Time for your eyedrops
19. Check blood sugar level
20. Check blood pressure
21. Use your Nebulizer
22. Remember your meal
23. Take your liquid meds

**USER & CAREGIVER WORKSHEET***Interactive Medical Developments, LC*

Please use this form to provide user and caregiver contact information. When this is completed, either fax to or call your support center.

MD.2 Serial Number:
---------------------

**USER INFORMATION**

User Name:	Date of Birth:
Street Address:	Gender:    F    M
City:	State:                      Zip:
Phone Number (w/ Area Code):	
Time Zone:            ATL   EST   CST   MST   PST   AST   HI	

**CAREGIVER INFORMATION**

If a dosage is missed by the user, the MD.2 will call caregivers in the following order.

<b>Caregiver # 1</b>	Relationship to User:
Phone No :	Need to dial area code from User Home?    Y    N
Email:	FAX Number:

<b>Caregiver # 2</b>	Relationship to User:
Phone No :	Need to dial area code from User Home?    Y    N
Email:	FAX Number:

<b>Caregiver # 3</b>	Relationship to User:
Phone No :	Need to dial area code from User Home?    Y    N
Email:	FAX Number:

<b>Caregiver # 4</b>	Relationship to User:
Phone No :	Need to dial area code from User Home?    Y    N
Email:	FAX Number:

**RECORDKEEPING & DOCUMENTATION WORKSHEET**

**IMD**

User Name: _____ MD.2 Serial Number _____
---

***Customer Support Information (if available/applicable):***

Customer Support Organization/Healthcare Provider:
Contact Name:
Phone Number (w/ Area Code):
Fax:

***When would you like to schedule the set up of the MD.2?*** \_\_\_\_\_

(You should plan to schedule the set up at a time when you will be at the user's home and ready to install and load the machine with medications.)

*Signed:* \_\_\_\_\_ *Date:* \_\_\_\_\_

User Medication Schedule/Worksheet

User Name: \_\_\_\_\_ MD.2 Serial Number: \_\_\_\_\_

	Sunday	Monday	Tuesday	Wednesday	Thursday	Friday	Saturday
<b>Morning</b>							
Time:							
Message:							
<b>Mid-Morning</b>							
Time:							
Message:							
<b>Noon</b>							
Time:							
Message:							
<b>Mid-Afternoon</b>							
Time:							
Message:							
<b>Evening</b>							
Time:							
Message:							
<b>Night</b>							
Time:							
Message:							

*Dear Pharmacist or Physician,*

*Your client, \_\_\_\_\_, has recently installed  
(Your name)  
the MD.2 Personal Medication Dispensing System. This device reminds your  
client when to take their medication and then delivers it when the dispense  
button is pushed. The MD.2 can also remind your client of the correct way to  
take medications (with extra fluid; without food etc.) as well as what  
non-oral medications need to be taken.*

*The MD.2 can be loaded for 10 to 30 days depending on your client's  
dosing schedule. It would be very helpful if all of their medications were on  
the same 30-day refill cycle. Any assistance you can offer to achieve this will  
be of great help in your client's efforts to maintain or improve their health  
status.*

*Sincerely yours,*

*MD.2 User  
Your street address  
City, State zip*



*Interactive* **Medical Developments,** *L.C*